

## Datasheet

# Solenoid valves 2/2-way servo operated type EV220B 15–50



EV220B 15–50 is a universal indirect servo-operated 2/2-way solenoid valve program. Valve body in brass, dezincification resistant brass and stainless steel ensures that a broad variety of application can be covered.

Built-in pilot filter as standard, adjustable closing time and enclosures up to IP67 ensures optimal performance even under critical working conditions.

**Features and versions:**

- For water, steam, oil, compressed air and gases
- Flow range for water: 1.3 – 160 m<sup>3</sup>/h
- Differential pressure: 0.3 – 16 bar
- Media temperature from -30 – 140 °C
- Ambient temperature: Up to 80 °C
- Coil enclosure: Up to IP67
- Thread connections: From G ½ – G 2
- DN 15 – 50
- Viscosity: Up to 50 cSt
- Water hammer damped
- Built in filter for protection of pilot system
- Adjustable closing time available
- EV220B NC and NO brass version for neutral liquids and gasses
- EV220BD NC DZR version for neutral and slightly aggressive liquids and gases
- EV220BSS NC Stainless steel version for neutral and aggressive liquids and gases
- Also available with NPT thread.

## Solenoid valves, type EV220B 15–50

### Brass valve body, NC



Connection ISO228/1	Seal material	Orifice size	$k_v$ - value [m <sup>3</sup> /h]	Differential pressure min. to max. <sup>6)</sup> [bar]	Media temperature min. to max. [°C]	Code number
G ½	EPDM <sup>1)</sup>	15	4	0.3 – 16	-30 – 120 <sup>4)</sup>	<b>032U7115</b>
	NBR <sup>2)</sup>			0.3 – 16	-10 – 90	<b>032U7170</b>
	FKM <sup>3)</sup>			0.3 – 10	0 – 100 <sup>5)</sup>	<b>032U7116</b>
G ¾	EPDM <sup>1)</sup>	20	8	0.3 – 16	-30 – 120 <sup>4)</sup>	<b>032U7120</b>
	NBR <sup>2)</sup>			0.3 – 16	-10 – 90	<b>032U7171</b>
	FKM <sup>3)</sup>			0.3 – 10	0 – 100 <sup>5)</sup>	<b>032U7121</b>
G 1	EPDM <sup>1)</sup>	25	11	0.3 – 16	-30 – 120 <sup>4)</sup>	<b>032U7125</b>
	NBR <sup>2)</sup>			0.3 – 16	-10 – 90	<b>032U7172</b>
	FKM <sup>3)</sup>			0.3 – 10	0 – 100 <sup>5)</sup>	<b>032U7126</b>
G 1 ¼	EPDM <sup>1)</sup>	32	18	0.3 – 16	-30 – 120 <sup>4)</sup>	<b>032U7132</b>
	NBR <sup>2)</sup>			0.3 – 16	-10 – 90	<b>032U7173</b>
	FKM <sup>3)</sup>			0.3 – 10	0 – 100 <sup>5)</sup>	<b>032U7133</b>
G 1 ½	EPDM <sup>1)</sup>	40	24	0.3 – 16	-30 – 120 <sup>4)</sup>	<b>032U7140</b>
	NBR <sup>2)</sup>			0.3 – 16	-10 – 90	<b>032U7174</b>
	FKM <sup>3)</sup>			0.3 – 10	0 – 100 <sup>5)</sup>	<b>032U7141</b>
G 2	EPDM <sup>1)</sup>	50	40	0.3 – 16	-30 – 120 <sup>4)</sup>	<b>032U7150</b>
	NBR <sup>2)</sup>			0.3 – 16	-10 – 90	<b>032U7175</b>
	FKM <sup>3)</sup>			0.3 – 10	0 – 100 <sup>5)</sup>	<b>032U7151</b>

### Brass valve body, NO



Connection ISO228/1	Seal material	Orifice size	$k_v$ - value [m <sup>3</sup> /h]	Differential pressure min. to max. <sup>6)</sup> [bar]	Media temperature min. to max. [°C]	Code number
G ½	EPDM <sup>1)</sup>	15	4	0.3 – 16	-30 – 120 <sup>4)</sup>	<b>032U7117</b>
	NBR <sup>2)</sup>			0.3 – 16	-10 – 90	<b>032U7180</b>
	FKM <sup>3)</sup>			0.3 – 10	0 – 100 <sup>5)</sup>	<b>032U7118</b>
G ¾	EPDM <sup>1)</sup>	20	8	0.3 – 16	-30 – 120 <sup>4)</sup>	<b>032U7122</b>
	NBR <sup>2)</sup>			0.3 – 16	-10 – 90	<b>032U7181</b>
	FKM <sup>3)</sup>			0.3 – 10	0 – 100 <sup>5)</sup>	<b>032U7123</b>
G 1	EPDM <sup>1)</sup>	25	11	0.3 – 16	-30 – 120 <sup>4)</sup>	<b>032U7127</b>
	NBR <sup>2)</sup>			0.3 – 16	-10 – 90	<b>032U7182</b>
	FKM <sup>3)</sup>			0.3 – 10	0 – 100 <sup>5)</sup>	<b>032U7128</b>
G 1 ¼	EPDM <sup>1)</sup>	32	18	0.3 – 16	-30 – 120 <sup>4)</sup>	<b>032U7134</b>
	NBR <sup>2)</sup>			0.3 – 16	-10 – 90	<b>032U7183</b>
	FKM <sup>3)</sup>			0.3 – 10	0 – 100 <sup>5)</sup>	<b>032U7135</b>
G 1 ½	EPDM <sup>1)</sup>	40	24	0.3 – 10	-30 – 120 <sup>4)</sup>	<b>032U7142</b>
	NBR <sup>2)</sup>			0.3 – 10	-10 – 90	<b>032U7184</b>
	FKM <sup>3)</sup>			0.3 – 10	0 – 100 <sup>5)</sup>	<b>032U7143</b>
G 2	EPDM <sup>1)</sup>	50	40	0.3 – 10	-30 – 120 <sup>4)</sup>	<b>032U7152</b>
	NBR <sup>2)</sup>			0.3 – 10	-10 – 90	<b>032U7185</b>
	FKM <sup>3)</sup>			0.3 – 10	0 – 100 <sup>5)</sup>	<b>032U7153</b>

- <sup>1)</sup> EPDM is recommended for water.
- <sup>2)</sup> NBR is suitable for oil, water and air
- <sup>3)</sup> FKM is suitable for oil and air. For water at max. +60 °C
- <sup>4)</sup> Low pressure steam, 4 bar: Max. +140 °C  
BA a.c./d.c. and BB/BE d.c. coils: Max. +100 °C  
BO and BP coils: Max. +90 °C
- <sup>5)</sup> For water: Max. +60 °C  
BO and BP coils: Max. +90 °C
- <sup>6)</sup> Only 10 bars on liquids (NO)

## Solenoid valves, type EV220B 15–50

### Technical data, brass valve body, NC and NO

Main type	EV220B 15B	EV220B 20B	EV220B 25B	EV220B 32B	EV220B 40B	EV220B 50B
Time to open [ms] <sup>1)</sup>	40	40	300	1000	1500	5000
Time to close [ms] <sup>1)</sup>	350	1000	1000	2500	4000	10000

<sup>1)</sup>The times are indicative and apply to water. The exact times will depend on the pressure conditions.  
Closing times can be changed by replacement of the equalising orifice.

Installation	Optional, but vertical solenoid system is recommended.		
Max. test pressure	25 bar		
Viscosity	Max. 50 cSt		
Materials	Valve body:	Brass	W.no. 2.0402
	Armature:	Stainless steel	W.no. 1.4105/AISI 430 FR
	Armature tube:	Stainless steel	W.no. 1.4306/AISI 304 L
	Armature stop:	Stainless steel	W.no. 1.4105/AISI 430 FR
	Springs	Stainless steel	W.no. 1.4310/AISI 301
	O-rings:	EPDM, FKM or NBR	
	Valve plate:	EPDM, FKM or NBR	
Diaphragm:	EPDM, FKM or NBR		

## Solenoid valves, type EV220B 15–50

### Dezincification resistant brass (DZR) valve body, NC



Connection ISO228/1	Seal material	Orifice size	$k_v$ -value [m <sup>3</sup> /h]	Differential pressure Min. – max. [bar]	Media temperature min. to max. [°C]	Code number
G ½	EPDM <sup>1)</sup>	15	4	0.3 – 16	-30 – 120 <sup>2)</sup>	<b>032U5815</b>
G ¾		20	8			<b>032U5820</b>
G 1		25	11			<b>032U5825</b>
G 1 ¼		32	18			<b>032U5832</b>
G 1 ½		40	24			<b>032U5840</b>
G 2		50	40			<b>032U5850</b>

<sup>1)</sup> EPDM is recommended for water.

<sup>2)</sup> Low pressure steam, 4 bar: Max. +140 °C  
 BA a.c./d.c. and BB/BE d.c. coils: Max. +100 °C  
 BO and BP coils: Max. +90 °C

### Technical data, dezincification resistant brass (DZR) valve body, NC

Main type	EV220B 15BD	EV220B 20BD	EV220B 25BD	EV220B 32BD	EV220B 40BD	EV220B 50BD
Time to open [ms] <sup>1)</sup>	40	40	300	1000	1500	5000
Time to close ms] <sup>1)</sup>	350	1000	1000	2500	4000	10000

<sup>1)</sup>The times are indicative and apply to water. The exact times will depend on the pressure conditions.  
 Closing times can be changed by replacement of the equalising orifice.

Installation	Optional, but vertical solenoid system is recommended.		
Max. test pressure	25 bar		
Viscosity	Max. 50 cSt		
Materials	Valve body:	Dezincification resistant brass (DZR)	CuZn36Pb2As/CZ132
	Armature:	Stainless steel	W.no. 1.4105/AISI 430 FR
	Armature tube:	Stainless steel	W.no. 1.4306/AISI 304 L
	Armature stop:	Stainless steel	W.no. 1.4105/AISI 430 FR
	Springs	Stainless steel	W.no. 1.4310/AISI 301
	Orifices	Stainless steel	W.no. 1.4404/AISI 316L
	Valve seat	Stainless steel	W.no. 1.4404/AISI 316L
	O-rings	EPDM	
Valve plate	EPDM		
Diaphragm	EPDM		

## Solenoid valves, type EV220B 15–50

### Stainless steel valve body, NC



Connection ISO228/1	Seal material	Orifice size	$k_v$ - value [m <sup>3</sup> /h]	Differential pressure min. – max. [bar]	Media temperature min. to max. [°C]	Code number
G ½	EPDM <sup>1)</sup>	15	4	0.3 – 16	-30 – 120 <sup>3)</sup>	<b>032U8500</b>
	FKM <sup>2)</sup>			0.3 – 10	0 – 100 <sup>4)</sup>	<b>032U8506</b>
G ¾	EPDM <sup>1)</sup>	20	8	0.3 – 16	-30 – 120 <sup>3)</sup>	<b>032U8501</b>
	FKM <sup>2)</sup>			0.3 – 10	0 – 100 <sup>4)</sup>	<b>032U8507</b>
G 1	EPDM <sup>1)</sup>	25	11	0.3 – 16	-30 – 120 <sup>3)</sup>	<b>032U8502</b>
	FKM <sup>2)</sup>			0.3 – 10	0 – 100 <sup>4)</sup>	<b>032U8508</b>
G 1 ¼	EPDM <sup>1)</sup>	32	18	0.3 – 16	-30 – 120 <sup>3)</sup>	<b>032U8503</b>
	FKM <sup>2)</sup>			0.3 – 10	0 – 100 <sup>4)</sup>	<b>032U8509</b>
G 1 ½	EPDM <sup>1)</sup>	40	24	0.3 – 16	-30 – 120 <sup>3)</sup>	<b>032U8504</b>
	FKM <sup>2)</sup>			0.3 – 10	0 – 100 <sup>4)</sup>	<b>032U8510</b>
G 2	EPDM <sup>1)</sup>	50	40	0.3 – 16	-30 – 120 <sup>3)</sup>	<b>032U8505</b>
	FKM <sup>2)</sup>			0.3 – 10	0 – 100 <sup>4)</sup>	<b>032U8511</b>

<sup>1)</sup> EPDM is recommended for water.  
(steam max. +140° C / 4 bar).

<sup>2)</sup> FKM is suitable for oil and air. For water at max. +60 °C

<sup>3)</sup> Low pressure steam, 4 bar: Max. +140 °C  
BA a.c./d.c. and BB/BE d.c. coils: Max. +100 °C  
BO and BP coils: Max. +90 °C

<sup>4)</sup> For water: Max. +60 °C  
BO and BP coils: Max. +90 °C

### Technical data, stainless steel valve body, NC

Main type	EV220B 15SS	EV220B 20SS	EV220B 25SS	EV220B 32SS	EV220B 40SS	EV220B50SS
Time to open [ms] <sup>1)</sup>	40	40	300	1000	1500	5000
Time to close [ms] <sup>1)</sup>	350	1000	1000	2500	4000	10000

<sup>1)</sup>The times are indicative and apply to water. The exact times will depend on the pressure conditions.  
Closing times can be changed by replacement of the equalising orifice.

Installation	Optional, but vertical solenoid system is recommended.		
Max. test pressure	25 bar		
Viscosity	Max. 50 cSt		
Materials	Valve body:	Stainless steel	W.no. 1.4581/AISI 318
	Armature:	Stainless steel	W.no. 1.4105/AISI 430 FR
	Armature tube:	Stainless steel	W.no. 1.4306/AISI 304 L
	Armature stop:	Stainless steel	W.no. 1.4105/AISI 430 FR
	Springs:	Stainless steel	W.no. 1.4310/AISI 301
	Orifices:	Stainless steel	W.no. 1.4404/AISI316L
	O-rings:	EPDM or FKM	
	Valve plate:	EPDM or FKM	
Diaphragm:	EPDM or FKM		

**Solenoid valves, type EV220B 15–50**

**Dimensions and weight: Brass, DZR brass and stainless steel, NC and NO**

Type	Weight gross, valve body without coil [kg]	L [mm]	B [mm]	B <sub>1</sub> [mm] / coil type				H [mm]	H <sub>1</sub> [mm]
				BA	BB/BE	BG/BO	BP		
EV220B 15	0,7	80,0	52,0	32	46	68	45	99	15,0
EV220B 20	0,9	90,0	58,0	32	46	68	45	103	18,0
EV220B 25	1,3	109,0	70,0	32	46	68	45	113	22,0
EV220B 32	2,0	120,0	82,0	32	46	68	45	120	27,0
EV220B 40	3,0	130,0	95,0	32	46	68	45	129	32,0
EV220B 50	4,8	162,0	113,0	32	46	68	45	135	37,0

**Dimensions**

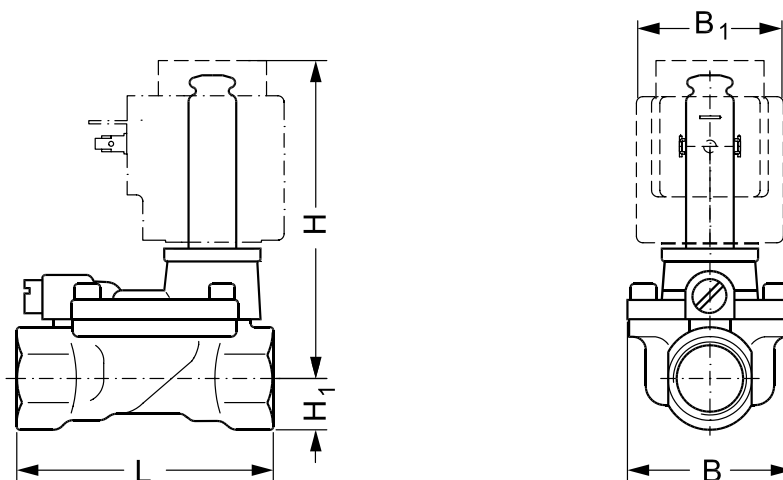

**Solenoid valves, type EV220B 15–50**
**Below coils can be used with EV220B 15–50**

Coil	Type	Power consumption	Enclosure	Features
	BA / BD, screw on	9 W a.c. 15 W d.c.	IP00 with spade connector	IP20 with protective cap, IP65 with cable plug
	BB, clip on	10 W a.c. 18 W d.c.	IP00 with spade connector	IP20 with protective cap, IP65 with cable plug
	BE, clip on	10 W a.c. 18 W d.c.	IP67	With terminal box
	BF, clip on	10 W a.c. 18 W d.c.	IP67	With 1 m cable
	BG, clip on	12 W a.c. 20 W d.c.	IP67	With terminal box
	BN, clip on	20 W 26 VA	IP67	Hum free With terminal box and 1 m cable
	BO, screw on	10 W 21 VA	IP67 only including seal kit 018Z0090	For explosion-risk environment zone 1. With terminal box and 5 m cable
	BP, screw on	12 W 10.5 W	IP67 only including seal kit 018Z0090	For explosion-risk environment zone 1. With 3 m cable

For further information and for ordering, see separate data sheet for coils.

## Solenoid valves, type EV220B 15-50

### Accessories: Cable plug

Application	Code number
GDM 2011 (grey) cable plug according to DIN 43650-A PG11	<b>042N0156</b>

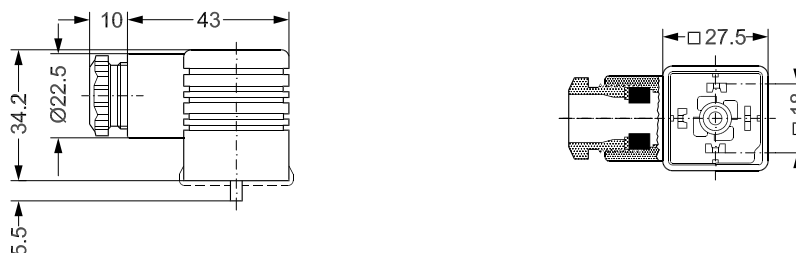

### Universal electronic multi-timer, type ETM



Application	Voltage	To use with coil:	Ambient temperature [°C]	Code number
External adjustable timing from 1 to 45 minutes with 1 to 15 seconds drain open. With manual override (test button). Electrical connection DIN 43650 A / EN 175 301-803-A	24 – 240 V a.c.	BA, BD, BB	-10 – 50	<b>042N0185</b>

- Outside adjustments
- Light weight and small size
- External adjustable timing from 1 minute to 45 minutes with 1 to 15 seconds drain open
- One solid state timer fits all coil voltages from 24 to 240 V a.c.
- Light diodes for indication
- All in one unit
- Manual override (test button)

### Technical data

Type	ET 20 M
Voltage	24 – 240 V a.c./ 50-60 Hz.
Power rating	Max. 20 Watt
Enclosure	IP00, IP65 with power connector (cable plug)
Electrical connection	DIN connector (DIN 43650-A)
Ambient operating temperature range	-10 – 50 °C
Function	Start with pulse
Interval timer	1 – 45 min.
"On" timer	1 – 15 sec.
Weight	0.084 kg

### Dimensions

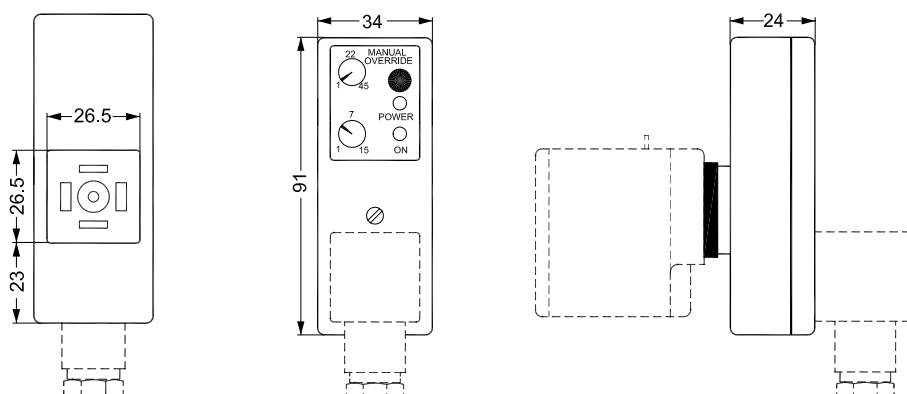



## Solenoid valves, type EV220B 15–50

### Manuel override unit, tool operated

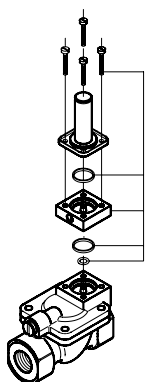

Material	Code number
Brass, size DN 15–32	<b>032U0150</b>
Stainless steel	<b>032U0149</b>

Used for manual override in event of power failure.  
Note: Valve height is increased by 16 mm.

**The unit consists of:**  
Manual override body  
4 screws  
3 o-rings



### Manual override unit, hand operated

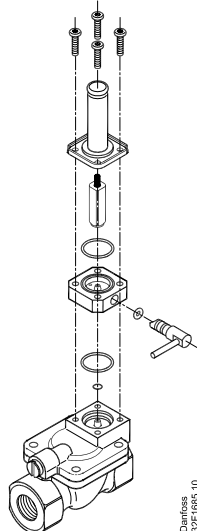

Material	Code number
Stainless steel, seal EPDM	<b>032U7390</b>

Used for manual override in event of power failure.

**The unit consists of:**  
Armature incl. closing spring  
Armature tube  
Stainless steel valve body  
O-ring 3.68 x 1.78  
O-ring 19 x 1.5  
O-ring 5 x 2.5  
4 screws  
4 nuts for transportation purpose only



### Isolating diaphragm kit

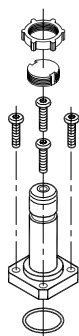

Seal material	Code number
EPDM	<b>042U1009</b>
FKM	<b>042U1010</b>

EPDM is recommended for water.  
FKM is suitable for oil and air. For water at max.+60 °C

The isolating diaphragm design ensures that no fluid enters the armature area, which gives the following advantages:  
The valve is resistant to aggressive fluids, impurities in the fluid and to calcarous and scale deposits.

**The kit contains:**  
Assembled isolating unit  
O-ring  
4 screws  
Locking button  
Nut for the coil



**Equalizing orifice**

**The kit comprises:**

An equalizing orifice including O-ring and gasket. The valve's closing time can be changed by installing an equalizing orifice of a size which deviates from the standard valve:

- A shorter closing time is obtained with a larger orifice (the shorter closing time, the greater risk of water hammering)
- A longer closing time is obtained with a smaller orifice.

Equalizing orifice size mm	Seal material	Applicable in	Code number	
			Brass	DZR brass <sup>3)</sup> / Stainless steel
0.5	EPDM <sup>1)</sup>	EV220B 15 EV220B 20	<b>032U0082</b>	<b>032U6310</b>
0.8	EPDM <sup>1)</sup>	EV220B 25 EV220B 32 EV220B 40	<b>032U0084</b>	<b>032U6311</b>
1.2	FKM <sup>2)</sup>	EV220B 25 EV220B 32	<b>032U0085</b>	<b>032U6314</b>
1.2	EPDM <sup>1)</sup>	EV220B 50	<b>032U0086</b>	<b>032U6312</b>
1.4	FKM <sup>2)</sup>	EV220B 40 EV220B 50	<b>032U0087</b>	<b>032U6315</b>

**Adjustable orifice**

**The kit comprises:**

An adjustable orifice including O-ring and gasket.

The valves closing time can be adjusted by turning the setting screw.

Orifice	Seal material	Applicable in	Material	Code number
Adjustable	EPDM <sup>1)</sup>	All EV220B 15–50 valves	Brass	<b>032U0682</b>
Adjustable	FKM <sup>2)</sup>		Brass	<b>032U0683</b>

- <sup>1)</sup> Approved by WRAS.  
Approved by Attestation de Conformite Sanitaire (ACS)  
EPDM is recommended for water. (Steam max. 40 °C / 4 bar)
- <sup>2)</sup> FKM is suitable for oil and air. For water at max. 60 °C.
- <sup>3)</sup> Dezincification resistant brass.

## Solenoid valves, type EV220B 15-50

### Spare parts kit, NC

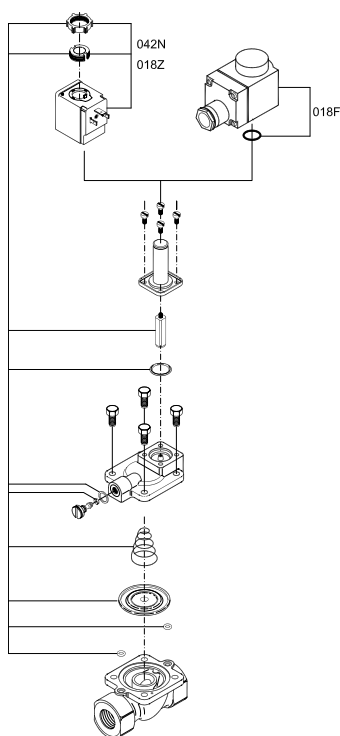

Brass versions		
Type	Seal material	Code number
EV220B 15	EPDM <sup>1)</sup>	<b>032U1071</b>
EV220B 15	FKM <sup>2)</sup>	<b>032U1072</b>
EV220B 15	NBR <sup>3)</sup>	<b>032U6013</b>
EV220B 20	EPDM <sup>1)</sup>	<b>032U1073</b>
EV220B 20	FKM <sup>2)</sup>	<b>032U1074</b>
EV220B 20	NBR <sup>3)</sup>	<b>032U6014</b>
EV220B 25	EPDM <sup>1)</sup>	<b>032U1075</b>
EV220B 25	FKM <sup>2)</sup>	<b>032U1076</b>
EV220B 25	NBR <sup>3)</sup>	<b>032U6015</b>
EV220B 32	EPDM <sup>1)</sup>	<b>032U1077</b>
EV220B 32	FKM <sup>2)</sup>	<b>032U1078</b>
EV220B 32	NBR <sup>3)</sup>	<b>032U6016</b>
EV220B 40	EPDM <sup>1)</sup>	<b>032U1079</b>
EV220B 40	FKM <sup>2)</sup>	<b>032U1080</b>
EV220B 40	NBR <sup>3)</sup>	<b>032U6017</b>
EV220B 50	EPDM <sup>1)</sup>	<b>032U1081</b>
EV220B 50	FKM <sup>2)</sup>	<b>032U1082</b>
EV220B 50	NBR <sup>3)</sup>	<b>032U6018</b>

DZR brass <sup>4)</sup> and stainless steel versions		
Type	Seal material	Code number
EV220B 15	EPDM <sup>1)</sup>	<b>032U6320</b>
EV220B 15	FKM <sup>2)</sup>	<b>032U6326</b>
EV220B 20	EPDM <sup>1)</sup>	<b>032U6321</b>
EV220B 20	FKM <sup>2)</sup>	<b>032U6327</b>
EV220B 25	EPDM <sup>1)</sup>	<b>032U6322</b>
EV220B 25	FKM <sup>2)</sup>	<b>032U6328</b>
EV220B 32	EPDM <sup>1)</sup>	<b>032U6323</b>
EV220B 32	FKM <sup>2)</sup>	<b>032U6329</b>
EV220B 40	EPDM <sup>1)</sup>	<b>032U6324</b>
EV220B 40	FKM <sup>2)</sup>	<b>032U6330</b>
EV220B 50	EPDM <sup>1)</sup>	<b>032U6325</b>
EV220B 50	FKM <sup>2)</sup>	<b>032U6331</b>

- 1) Approved by WRAS.  
Approved by Attestation de Conformite Sanitaire (ACS)  
EPDM is recommended for water. (Steam max. 140 °C / 4 bar).
- 2) FKM is suitable for oil and air. For water at max. 60 °C
- 3) NBR is suitable for oil, water and air
- 4) Dezincification resistant brass

#### The kit contains:

Locking button and nut for the coil  
Armature with valve plate and spring  
O-ring for the armature tube  
Spring and diaphragm  
2 O-rings for the pilot system  
O-ring and gasket for the equalising orifice



### Spare parts kit, NO

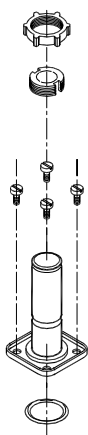

Type	Seal material	Code number
EV220B 15-50	EPDM <sup>1)</sup>	<b>032U0296</b>
	FKM <sup>2)</sup>	<b>032U0295</b>
	NBR <sup>3)</sup>	<b>032U0299</b>

- 1) EPDM is recommended for water. (Steam max. 140 °C / 4 bar).
- 2) FKM is suitable for oil and air. For water at max. +60 °C
- 3) NBR is suitable for oil, water and air.

#### The kit contains:

Locking button and nut for the coil  
NO actuator unit  
O-ring for the armature unit



**Function**

**NC, brass, DZR brass and stainless steel**

**Coil voltage disconnected (closed):**

When the voltage is disconnected, the valve plate (3) is pressed down against the pilot orifice (4) by the armature spring (2). The pressure across the diaphragm (5) is built up via the equalising orifice (7). The diaphragm closes the main orifice (6) as soon as the pressure across the diaphragm is equivalent to the inlet pressure. The valve will be closed for as long as the voltage to the coil is disconnected.

**Coil voltage connected (open):**

When voltage is applied to the coil (1), the pilot orifice (4) is opened. As the pilot orifice is larger than the equalising orifice (7), the pressure across the diaphragm (5) drops and therefore it is lifted clear of the main orifice (6). The valve is now open for unimpeded flow and will be open for as long as the minimum differential pressure across the valve is maintained, and for as long as there is voltage to the coil.

1. Coil
2. Armature spring
3. Valve plate
4. Pilot orifice
5. Diaphragm
6. Main orifice
7. Equalising orifice

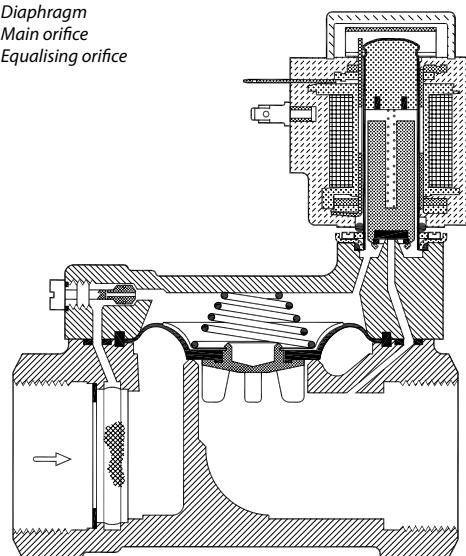

**Function**

**NO, brass, DZR brass and stainless steel**

**Coil voltage disconnected (open):**

When the voltage to the coil (2) is disconnected, the pilot orifice (4) is open. As the pilot orifice is larger than the equalising orifice (7), the pressure across the diaphragm (5) drops and therefore it is lifted clear of the main orifice (6). The valve will be open for as long as the minimum differential pressure across the valve is maintained, and for as long as the voltage to the coil is disconnected.

**Coil voltage connected (closed):**

When voltage is applied to the coil, the valve plate (3) is pressed down against the pilot orifice (4). The pressure across the diaphragm (5) is built up via the equalising orifice (7). The diaphragm closes the main orifice (6) as soon as the pressure across the diaphragm is equivalent to the inlet pressure. The valve will be closed for as long as there is voltage to the coil.

1. Armature
2. Coil
3. Valve plate
4. Pilot orifice
5. Diaphragm
6. Main orifice
7. Equalising orifice

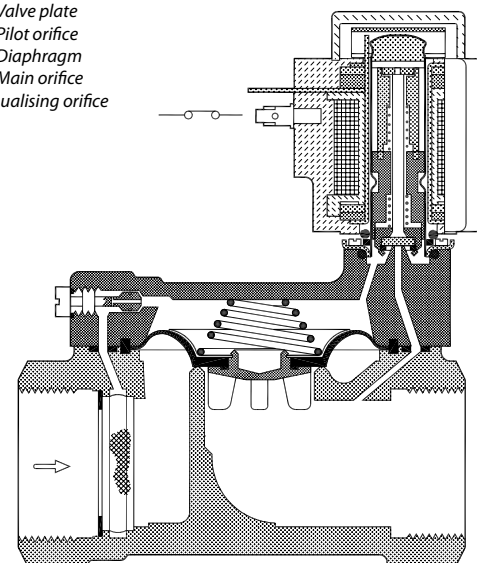

## Solenoid valves type EV220B 15-50

### Capacity diagrams:

Example, water:  
Capacity for EV220B 15B at differential pressure of 3 bar.  
Approx. 7 m<sup>3</sup>/h

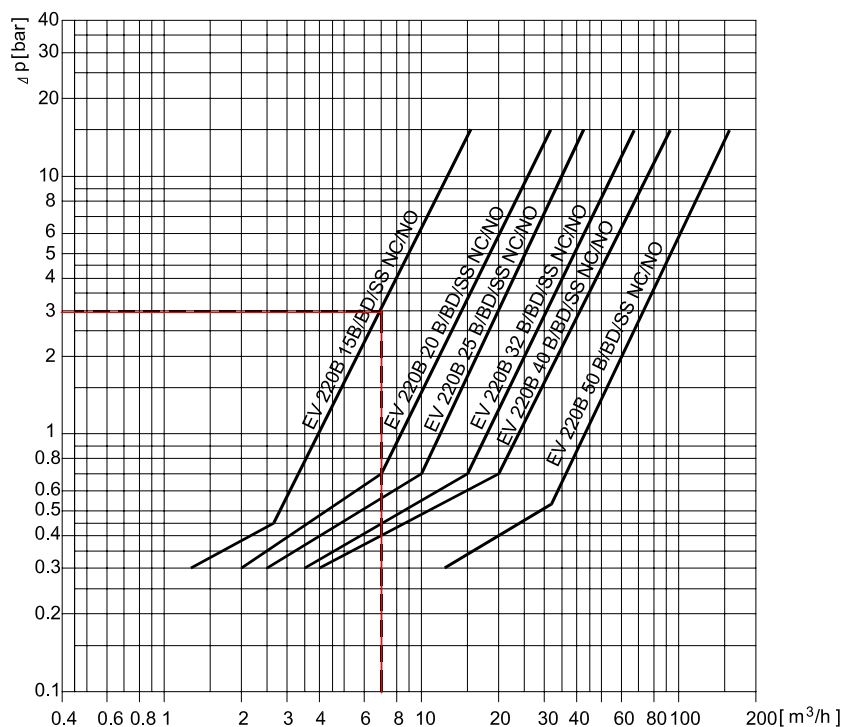

Example, air:  
Capacity for EV220B 15B at inlet pressure ( $p_1$ ) of 5 bar and outlet pressure ( $p_2$ ) of 3.5 bar: Approx. 245 Nm<sup>3</sup>/h

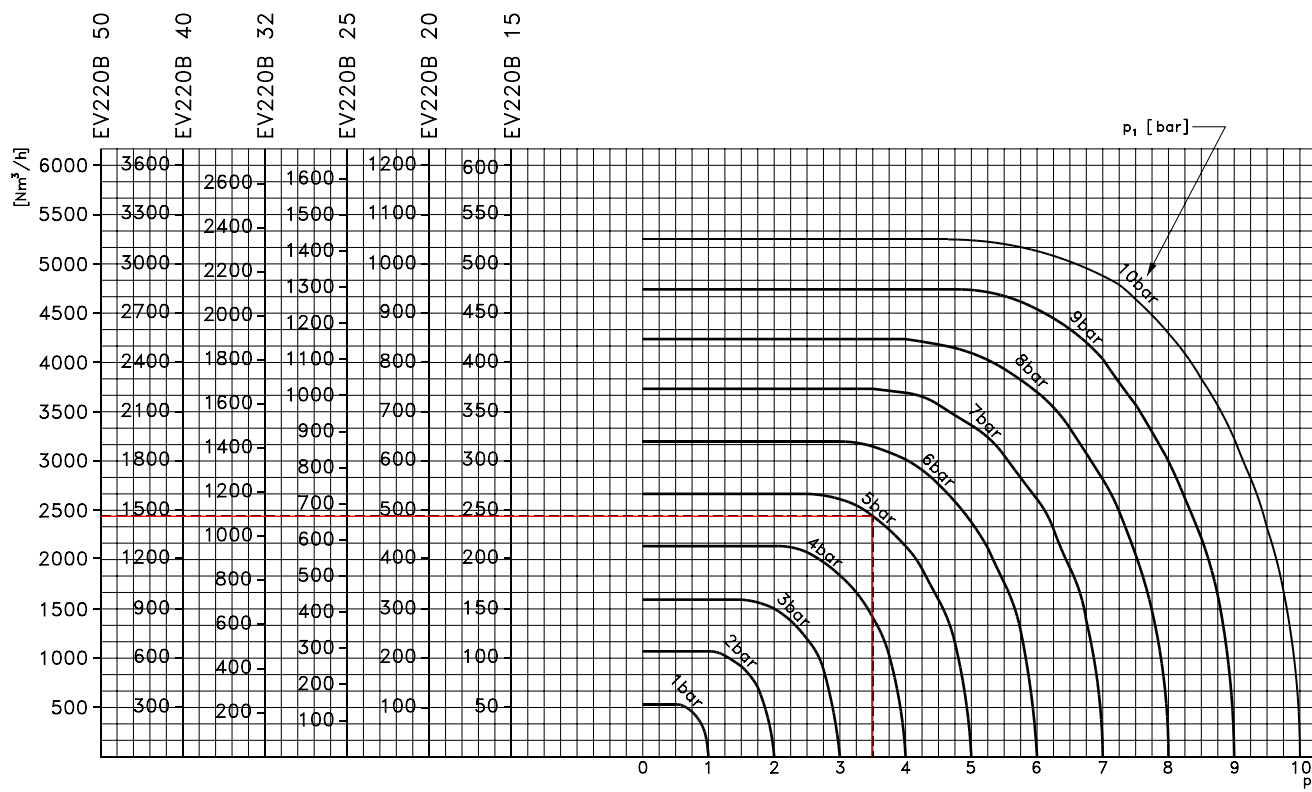

Danfoss can accept no responsibility for possible errors in catalogues, brochures and other printed material. Danfoss reserves the right to alter its products without notice. This also applies to products already on order provided that such alterations can be made without consequential changes being necessary in specifications already agreed.

All trademarks in this material are property of the respective companies. Danfoss and the Danfoss logotype are trademarks of Danfoss A/S. All rights reserved.